

Lâminas e acessórios
Cuchillas y accesorios

12



araújo&silva
ferramentas de corte

JÁ MEDIU A SUA PRODUTIVIDADE?



A Araujo&Silva, Lda. desenvolve ferramentas especiais, proporcionando aos seus clientes as soluções mais rentáveis.

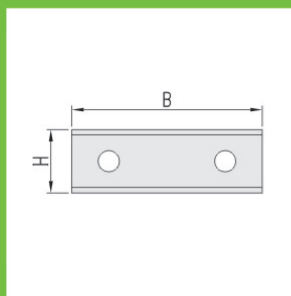
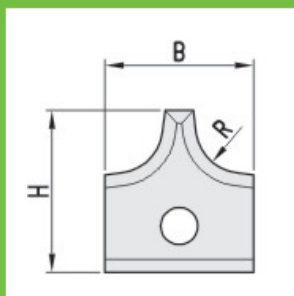
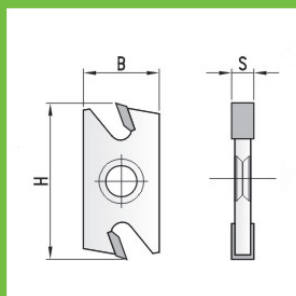

araújo&silva
ferramentas de corte

ESPECIALISTAS EM FERRAMENTA DE CORTE

www.araujosilva.pt



HW

B	H	S	α		Ref.
Tipo 1					
7,5	12	1,5	35°	ASF1	5000.01.1
	12	1,5	45°	AS15	5000.02.0
8,6	12	1,5	35°	ASF1	5000.03.1
9,6	12	1,5	35°	ASF1	5000.04.1
	12	1,5	45°	AS15	5000.05.0
10,5	12	1,5	35°	ASF1	5000.17.1
11	12	1,5	35°	ASF1	5000.18.1
11,6	12	1,5	35°	ASF1	5000.06.1
	12	1,5	45°	AS15	5000.07.0
13	12	1,5	35°	ASF1	5000.19.1
14,6	12	1,5	35°	ASF1	5000.08.1
15	12	1,5	35°	ASF1	5000.09.1
	12	1,5	45°	AS15	5000.10.0
15,7	12	1,5	35°	ASF1	5000.20.1
16	12	1,5	35	ASF1	5000.21.1
17	12	1,5	35°	ASF1	5000.11.1
17,6	12	1,5	35°	ASF1	5000.22.1
20	12	1,5	35°	ASF1	5000.12.1
	12	1,5	35°	ASMG03	5000.13.2
	12	1,5	35°	ASMG02	5000.23.3
	12	1,5	45	AS15	5000.15.0
21,6	12	1,5	35°	ASF1	5000.24.1
24,7	12	1,5	35°	ASF1	5000.17.1
24,7	12	1,5	35	ASF1	5001.17.1
30	12	1,5	35°	ASF1	5001.01.1
	12	1,5	35°	ASMG02	5001.17.3
	12	1,5	35	ASMG03	5001.02.2
	12	1,5	45°	AS15	5001.04.0
40	12	1,5	35°	ASF1	5001.05.1
	12	1,5	45°	AS15	5001.06.0
50	12	1,5	35°	ASF1	5001.07.1
	12	1,5	35°	ASMG02	5001.08.3
Tipo 2					
	12	1,5	35	ASMG03	5001.18.2
	12	1,5	45°	AS15	5001.10.0
60	12	1,5	35°	ASF1	5001.11.1
	12	1,5	45°	AS15	5001.12.0
80	13	2,2	35°	ASF1	5001.13.1
	13	2,2	45°	AS15	5001.14.0
100	13	2,2	35°	ASF1	5001.15.1
120	13	2,2	35°	ASF1	5001.16.1
Tipo 3					
14	14	2		ASF1	5002.01.1
	14	1,7			5002.02.1
	14	1,2			5002.03.1

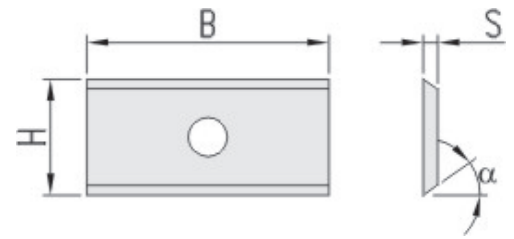

Tipo 1

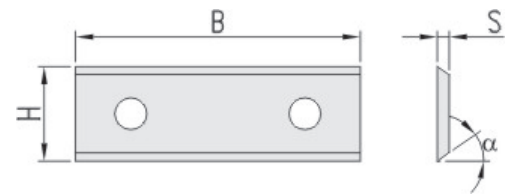

Tipo 2

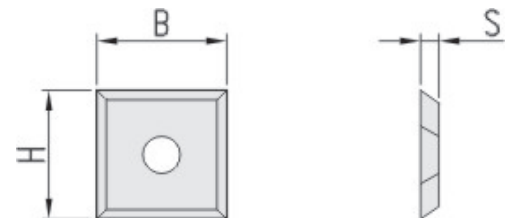

Tipo 3



5003/4 Lâminas reversíveis Cuchillas reversibles

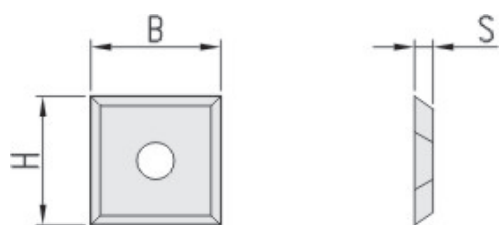

Tipo 1



Tipo 2

HW

B	H	S	R	Ref.
Tipo 1				
12	12	1,5		5003.01.1
	12	1.5		5003.02.3
14.3	14.3	2.5		5003.05.1
15	15	2.5	150	5003.06.1
17	17	2		5003.03.1
19	19	2		5003.04.1
Tipo 2				
29,5	12	1,5	ASF1	5004.01.1
49,5	12	1,5		5004.02.1
50	12	1.7		5004.03.1

5005 Lâminas reversíveis Cuchillas reversibles

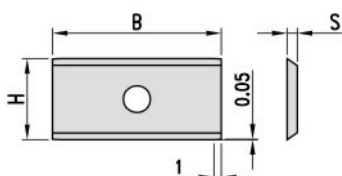

HW

B	H	S	Ref.
20	12	1,5	5005.01
24,7	12	1,5	5005.02
30	12	1.5	5005.03
50	12	1.5	5005.04

5006 Lâminas reversíveis Cuchillas reversibles

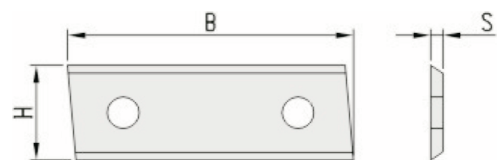

Tipo 1

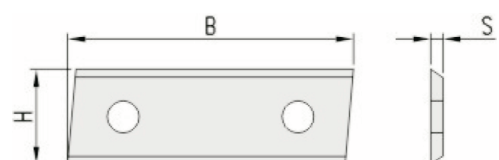

Tipo 2

HW

B	H	S	Ref.
Tipo 1			
20	12	1,5	5006.01
30	12	1,5	5006.02
50	12	1,5	5006.03
Tipo 2			
20	12	1,5	5006.51
30	12	1,5	5006.52
50	12	1,5	5006.53



			HW
B	H	S	Ref.
Tipo 1			
29.5	9	1,5	5007.01
	12	1,5	5007.02
49.5	9	1,5	5007.03
	12	1,5	5007.04

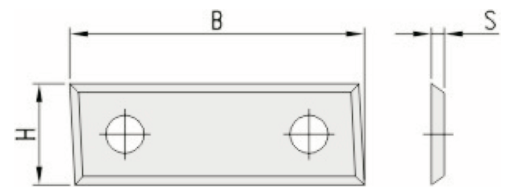

Lâminas reversíveis 5008/9
Cuchillas reversibles

			HW
B	H	S	Ref.
Tipo 1			
12	5,5	1,1	5008.01
20	5,5	1,1	5008.02
30	5,5	1,1	5008.03
40	5,5	1,1	5008.04
50	5,5	1,1	5008.05
Tipo 2			
12	5,5	1,1	5008.51
20	5,5	1,1	5008.52
30	5,5	1,1	5008.53
40	5,5	1,1	5008.54
50	5,5	1,1	5008.55

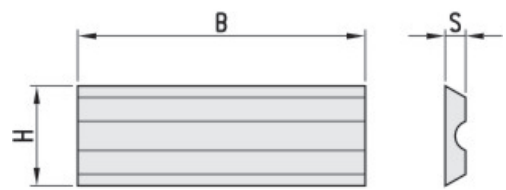

Tipo 1

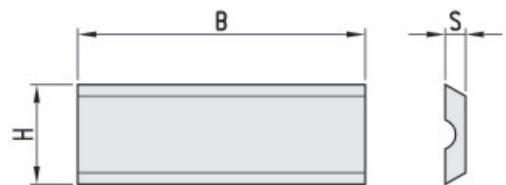

Tipo 2

Metal duro revestido - Metal duro recubierto

			HC
B	H	S	Ref.
20	5,5	1,1	5009.01
20	10	1,5	5009.02
30	10	1,5	5009.03
50	10	1,5	5009.04

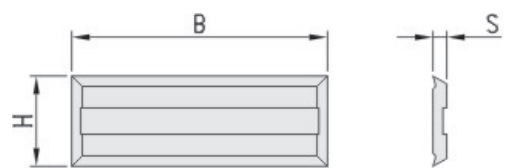



5010 Lâminas reversíveis Cuchillas reversibles

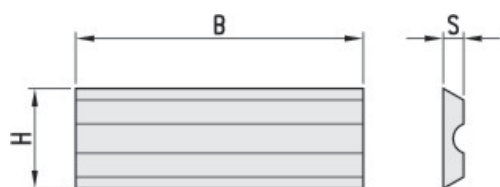

HW

B	H	S			Ref.
56	5,5	1,1	Adler		5010.01
60	5,5	1,1			5010.02
71	5,5	1,1			5010.03
75,5	5,5	1,1	AEG	TH75	5010.04
			Bosh	0590, P400, 1590, 1591	
			Festo	REP 75	
			Haffner	FH 222	
			Holz-Her	2223, 2286, 2320	
			Kress	Jet Start 6701, EH 6702	
			Mafell	HU 75	
			Metabo	6375	
			Scheer	MH 80, MH 75/3	
			Skil	98 H	
75,7	5,5	1,1	B & Decker	DN 750, BD 750	5010.05
				SR 600K	
78	5,5	1,1	Virutex	(E) HTH75A	5010.06
80,5	5,9	1,1	Elu	MFF80, MFF 40	5010.07
				ADE 80	
82	5,5	1,1	AEG	EH 82, EH 82S, EH 822	5010.08
				EH700, EH 450	
			Fein	HS 2151	
			Haffner	FH 224	
			Hitachi	F20, F20A, P20 SA, P 20V	
				FP 20A, FU 20 SA	
			Mafell	EHU 82, MHU 82, MHU 82 D	
			Makita	1100, 1125B, 1900B, 1923B	
				1923 H, 1001, 1901, 1923 HO	
			Metabo	Gustav, 4382, HO 0882	
			Bosh	PH0 150, 100, 200, 300	
82,7	5,5	1,1	B & Decker	DN 710, DN 712, DN 730	5010.09
				P71-02, PL 806	

12

Lâminas e acessórios · Cuchillas y accesorios

5011 Lâminas reversíveis Cuchillas reversibles

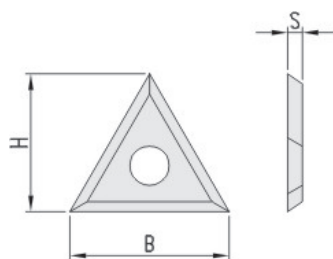

HW

B	H	S	R	Ref.
22	19	2		5011.01
	19	2	1	5011.02
	19	2	1	5011.03



				HW
B	H	S	R	Ref.
13	16	2	2	5012.01
	16	2	3	5012.02
16	16	2	4	5012.03
	20	21	2	5012.04
20	21	2	6	5012.05
	21	2	7	5012.06
21	21	2	8	5012.07
	26	24	2	5012.08
26	24	2	10	5012.09
	24	2	11	5012.10
24	24	2	12	5012.11
	24	2	13	5012.12
30	25	2	14	5012.13
	25	2	15	5012.14
25	2	16	5012.15	

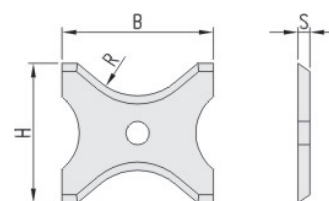

Lâminas perfiladas, não reversíveis 5025
Cuchillas perfiladas, no reversible

				HW
B	H	S	R	Ref.
16	17,5	2	2	5025.01
	17,5	2	3	5025.02
17,5	17,5	2	4	5025.03
	17,5	2	5	5025.04
17,5	2	6	5025.05	

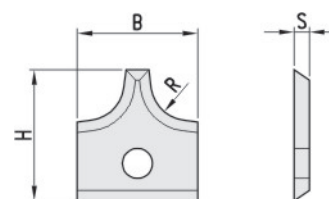

Lâminas perfiladas 5013
Cuchillas perfiladas

			HW
B	H	S	Ref.
18	18	1,95	5013.01
	18	2,45	5013.02
18	2,95	5013.03	

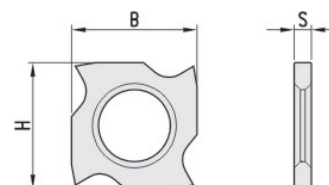

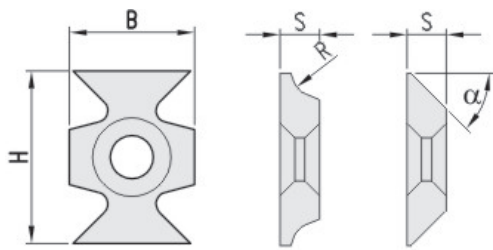
**5026/27****Chanfradores e redondeadores**
Cuchillas reversibles

HW · MEC

B	H	S	R / α	Ref.
16	22	5	45°	5026.01
	22	5	R1,5	5026.02
	22	5	R2	5026.03
	22	5	R2,5	5026.04
	22	5	R3	5026.05

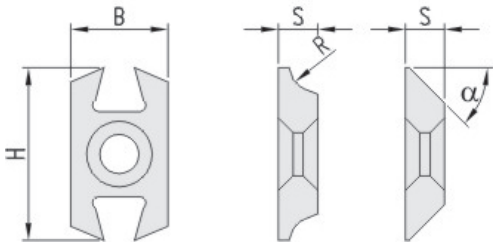

HW · MAN

B	H	S	R / α	Ref.
16	29	5	45°	5027.01
	29	5	R2	5027.02
	29	5	R3	5027.03

12

Láminas e accesorios · Cuchillas y accesorios

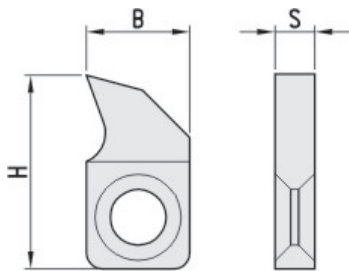
5028/29**Ranhuradores**
Ranuradores

HW · MEC

B	H	S	Ref.
16	25,5	4	5028.01
	25,5	5	5028.02
	25,5	6	5028.03

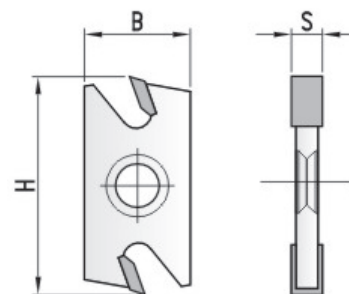

HW · MAN

B	H	S	Ref.
17	35	4	5029.01
	35	5	5029.02
	35	6	5029.03



			HL/HS · HW	
B	H	S	HS Ref. (18%W)	HW Ref.
120	25	3	5050.120.25	5051.120.25
130		3	5050.130.25	5051.130.25
150		3	5050.150.25	5051.150.25
180		3	5050.180.25	5051.180.25
200		3	5050.200.25	5051.200.25
250		3	5050.250.25	5051.250.25
260		3	5050.260.25	5051.260.25
310		3	5050.310.25	5051.310.25
350		3	5050.350.25	5051.350.25
80	30	3	5050.080.30	5051.080.30
100		3	5050.100.30	5051.100.30
120		3	5050.120.30	5051.120.30
130		3	5050.130.30	5051.130.30
150		3	5050.150.30	5051.150.30
170		3	5050.170.30	5051.170.30
180		3	5050.180.30	5051.180.30
200		3	5050.200.30	5051.200.30
220		3	5050.220.30	5051.220.30
230		3	5050.230.30	5051.230.30
240		3	5050.240.30	5051.240.30
250		3	5050.250.30	5051.250.30
260		3	5050.260.30	5051.260.30
300		3	5050.300.30	5051.300.30
350		3	5050.350.30	5051.350.30
400		3	5050.400.30	5051.400.30
410		3	5050.410.30	5051.410.30
450		3	5050.450.30	5051.450.30
500		3	5050.500.30	5051.500.30
510		3	5050.510.30	5051.510.30
530		3	5050.530.30	5051.530.30
600		3	5050.600.30	5051.600.30
610		3	5050.610.30	5051.610.30
630		3	5050.630.30	5051.630.30
640		3	5050.640.30	5051.640.30
350	35	3	5050.350.35	5051.350.35
400		3	5050.400.35	5051.400.35
410		3	5050.410.35	5051.410.35
460		3	5050.460.35	5051.460.35
500		3	5050.500.35	5051.500.35
510		3	5050.510.35	5051.510.35
520		3	5050.520.35	5051.520.35
530		3	5050.530.35	5051.530.35
600		3	5050.600.35	5051.600.35
610		3	5050.610.35	5051.610.35
630		3	5050.630.35	5051.630.35

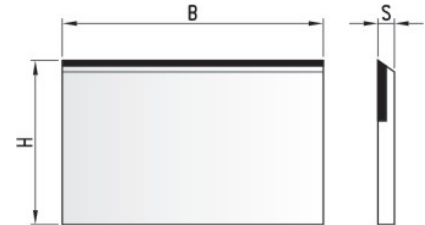
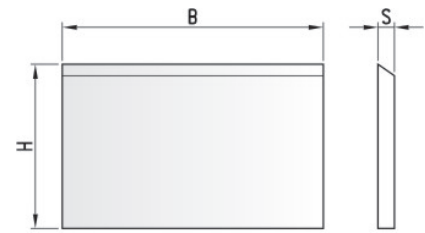

Para garlopa manual

B	H	S		HS Ref.	HW Ref.
178	25	3,2	Virutex	5050.078.25	5051.078.25
82	29	3	Makita	5050.082.29	5051.082.29

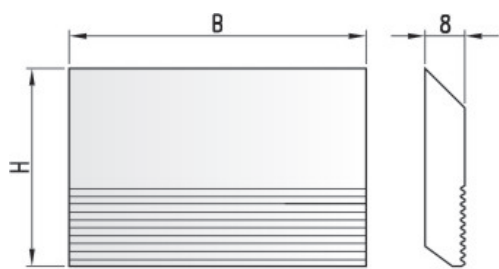

HS

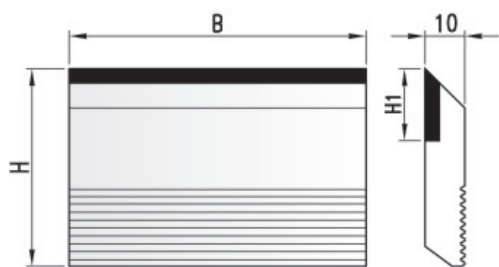

Lâmina calçada (HW)

HW · HSS

B	H	H1	HW Ref.	HSS Ref.
40	50	15	5055.040.50	5056.040.50
60			5055.060.50	5056.060.50
80			5055.080.50	5056.080.50
100			5055.100.50	5056.100.50
130			5055.130.50	5056.130.50
150			5055.150.50	5056.150.50
180			5055.180.50	5056.180.50
230			5055.230.50	5056.230.50
635			5055.635.50	5056.635.50
650			5055.650.50	5056.650.50
40	60	20	5055.040.60	5056.040.60
60			5055.060.60	5056.060.60
80			5055.080.60	5056.080.60
100			5055.100.60	5056.100.60
130			5055.130.60	5056.130.60
150			5055.150.60	5056.150.60
180			5055.180.60	5056.180.60
230			5055.230.60	5056.230.60
635			5055.635.60	5056.635.60
650			5055.650.60	5056.650.60
40	70	25	5055.040.70	5056.040.70
60			5055.060.70	5056.060.70
80			5055.080.70	5056.080.70
100			5055.100.70	5056.100.70
130			5055.130.70	5056.130.70
150			5055.150.70	5056.150.70
180			5055.180.70	5056.180.70
230			5055.230.70	5056.230.70
635			5055.635.70	5056.635.70
650			5055.650.70	5056.650.70

5060

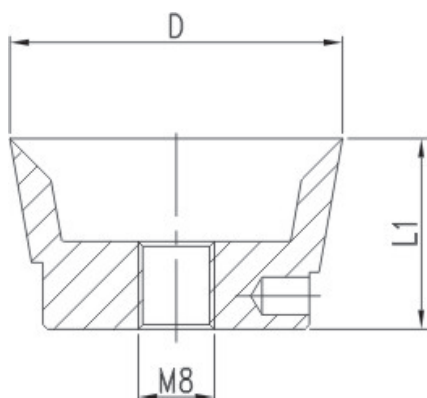
Buril para torno copiador
Buril forma vaso para torno copiador

HS

D	L1	Ref.
22	15	5060.022.15
30	19	5060.030.19
35	20	5060.035.20
45	26	5060.045.26
50	26	5060.050.26



HS

D	d	Ref.
25	6,2	5065.25.01
	8,2	5065.25.02
	10,2	5065.25.03
	12,2	5065.25.04

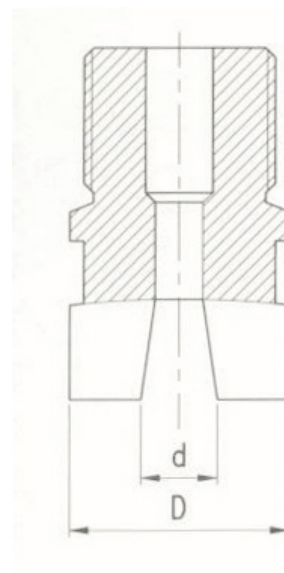

Buril copiador 5070
Gubia para torno copiador

HS

b	s	h	Ref.
25	9,5	100	HS 5070.25.01
	9,5	100	ST 5070.25.02
	9,5	100	HW 5070.25.03
40	15	110	HS 5070.40.01
	15	110	ST 5070.40.02
	15	110	HW 5070.40.03

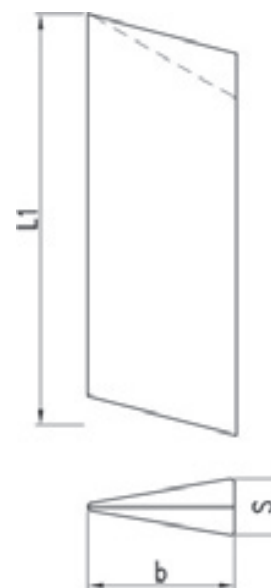

Buril copiador 5071
Gubia para torno copiador

HS

h	B	Ref.
16	150	5071.16.01
20	200	5071.20.01

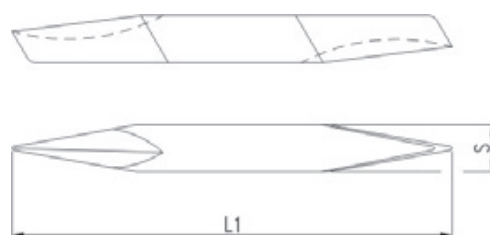

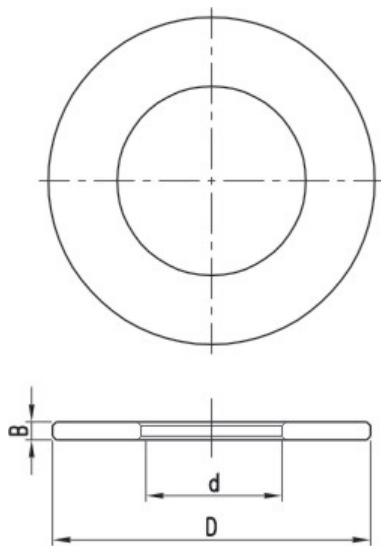

d	B	D	Ref.
30	0,1	50	5075.01
	0,2	50	5075.02
	0,5	50	5075.03
	1	50	5075.04
	2	50	5075.05
	5	50	5075.06
	7	50	5075.07
	10	50	5075.08
31,75	0,1	50	5075.09
	0,2	50	5075.10
	0,5	50	5075.11
	1	50	5075.12
	2	50	5075.13
	5	50	5075.14
	7	50	5075.15
	10	50	5075.16
35	0,1	55	5075.17
	0,2	55	5075.18
	0,5	55	5075.19
	1	55	5075.20
	2	55	5075.21
	5	55	5075.22
	7	55	5075.23
	10	55	5075.24
40	0,1	60	5075.25
	0,2	60	5075.26
	0,5	60	5075.27
	1	60	5075.28
	2	60	5075.29
	5	60	5075.30
	7	60	5075.31
	10	60	5075.32
50	0,1	70	5075.33
	0,2	70	5075.34
	0,5	70	5075.35
	1	70	5075.36
	2	70	5075.37
	5	70	5075.38
	7	70	5075.39
	10	70	5075.40
60	0,1	80	5075.41
	0,2	80	5075.42
	0,5	80	5075.43
	1	80	5075.44
	2	80	5075.45
	5	80	5075.46
	7	80	5075.47
	10	80	5075.48

Jogo de 7 anilhas separadoras 1x2, 1x1, 2x0,5, 2x0,2, 1x0,1

d	D	Ref.
30	50	5075.951
35	55	5075.952
40	60	5075.953
50	70	5075.954
60	80	5075.955



D	B	d	Ref.
35	2	30	5080.01
	5	30	5080.02
	10	30	5080.03
	15	30	5080.04
	20	30	5080.05
	30	30	5080.06
	40	30	5080.07
	50	30	5080.08
40	2	30	5080.09
	5	30	5080.10
	10	30	5080.11
	15	30	5080.12
	20	30	5080.13
	30	30	5080.14
	40	30	5080.15
	50	30	5080.16
40	2	31,75	5080.17
	5	31,75	5080.18
	10	31,75	5080.19
	15	31,75	5080.20
	20	31,75	5080.21
	30	31,75	5080.22
	40	31,75	5080.23
	50	31,75	5080.24
40	2	35	5080.25
	5	35	5080.26
	10	35	5080.27
	15	35	5080.28
	20	35	5080.29
	30	35	5080.30
	40	35	5080.31
	50	35	5080.32
45	2	30	5080.33
	5	30	5080.34
	10	30	5080.35
	15	30	5080.36
	20	30	5080.37
	30	30	5080.38
	40	30	5080.39
	50	30	5080.40
50	2	30	5080.41
	5	30	5080.42
	10	30	5080.43
	15	30	5080.44
	20	30	5080.45
	30	30	5080.46
	40	30	5080.47
	50	30	5080.48

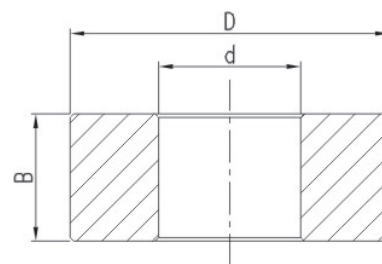

CONTINUA NA PÁGINA SEGUINTE
 continúa en la página siguiente



5080 Casquilhos de redução Casquillo de reducción sin borde

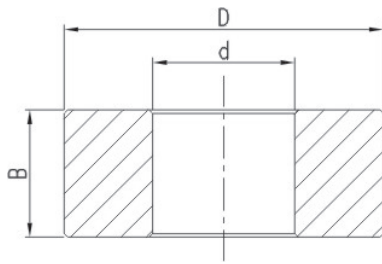

D	B	d	Ref.
50	2	35	5080.49
	5	35	5080.50
	10	35	5080.51
	15	35	5080.52
	20	35	5080.53
	30	35	5080.54
	40	35	5080.55
	50	35	5080.56
50	2	40	5080.57
	5	40	5080.58
	10	40	5080.59
	15	40	5080.60
	20	40	5080.61
	30	40	5080.62
	40	40	5080.63
	50	40	5080.64
50	2	45	5080.65
	5	45	5080.66
	10	45	5080.67
	15	45	5080.68
	20	45	5080.69
	30	45	5080.70

12

Lâminas e acessórios · Cuchillas y accesorios

5081/2 Casquilhos de redução com anel Casquillo de reducción con borde

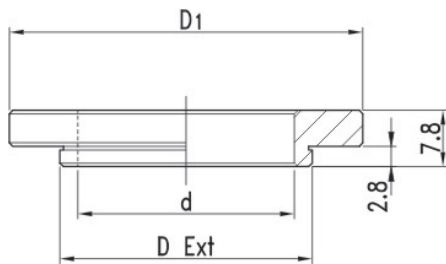

Tipo 1

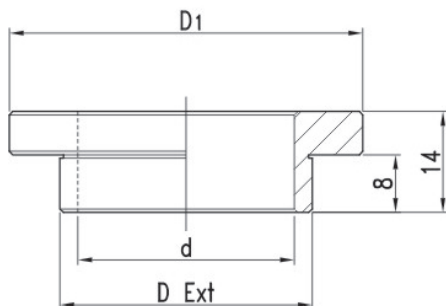

Tipo 2

d	DExt	D1	Ref. Tipo 1	Ref. Tipo 2
30	35	49	5081.01	5082.01
	40	54	5081.02	5082.02
	45	59	5081.03	5082.03
	50	64	5081.04	5082.04
31,75	35	49	5081.05	5082.05
	40	54	5081.06	5082.06
	45	59	5081.07	5082.07
	50	64	5081.08	5082.08
35	40	54	5081.09	5082.09
	45	59	5081.10	5082.10
	50	64	5081.11	5082.11
40	45	50	5081.12	5082.12
	50	64	5081.13	5082.13
45	50	64	5081.14	5082.14



d	B	D	Ref.
16	2	30	5083.01
20	2	30	5083.02
	2	32	5083.03
	2	35	5083.04
25	2	20	5083.05
	2	30	5083.06
	2	32	5083.07
	2	35	5083.08
25,4	2	32	5083.09
30	2	32	5083.10
	2	35	5083.11
32	2	35	5083.12
	2	40	5083.13
35	2	40	5083.14

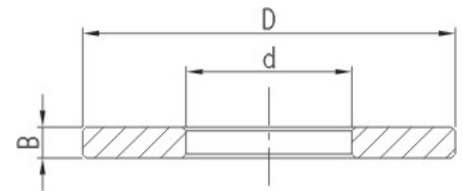

Jogo de casquilhos (para árvore de tupia)
Juego de anillos para tupi

5084

d	D	L	Ref.
30	43	200	5084.901
35	48	200	5084.902
40	54	200	5084.903
45	62	245	5084.904
50	65	245	5084.905

COMPOSIÇÃO DOS JOGOS - Composición de los juegos

L=200 2x5; 2x10; 3x20; 2x30; 1x50
L=245 3x5; 2x10; 1x20; 3x30; 5x50

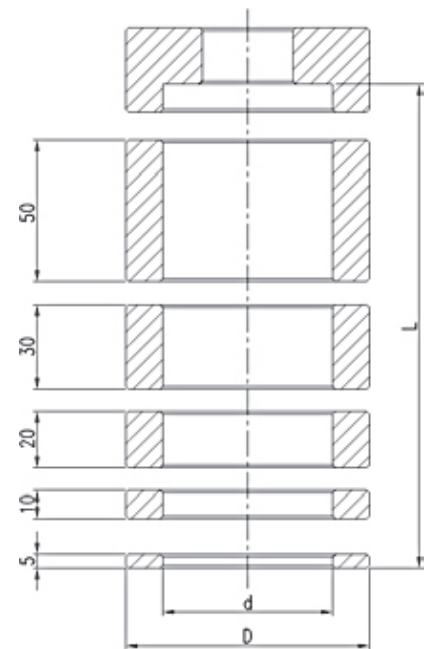

Rolamento
Rodamiento

5100

D	d	Ref.
9,5	3,1	5100.01
9,5	4,7	5100.02
12,7	4,7	5100.03
19	6	5100.04
22	8	5100.05
55	30	5100.06
62	35	5100.07
68	40	5100.08
75	45	5100.09
80	50	5100.10
69,85	31,75	5100.11

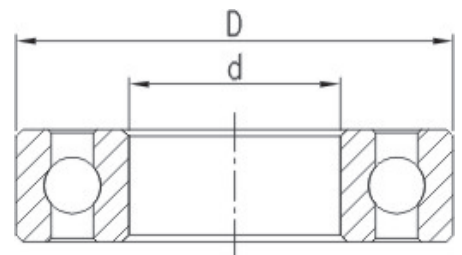



5101 Anel para rolamento copiador Anillo tope para rodamiento

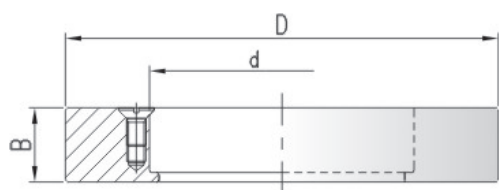

d	B	D	Ref.
55	15,5	70	5101.01
	15,5	75	5101.02
	15,5	80	5101.03
	15,5	85	5101.04
	15,5	86	5101.05
	15,5	90	5101.06
	15,5	94	5101.07
	15,5	95	5101.08
	15,5	100	5101.09
	15,5	105	5101.10
	15,5	110	5101.11
	15,5	115	5101.12
	15,5	120	5101.13
	15,5	125	5101.14
	15,5	130	5101.15
	15,5	135	5101.16
	15,5	140	5101.17
62	16,5	75	5101.18
	16,5	78	5101.19
	16,5	80	5101.20
	16,5	85	5101.21
	16,5	90	5101.22
	16,5	95	5101.23
	16,5	100	5101.24
	16,5	105	5101.25
	16,5	110	5101.26
	16,5	115	5101.27
	16,5	120	5101.28
	16,5	125	5101.29
	16,5	130	5101.30
	16,5	135	5101.31
	16,5	140	5101.32
68	17,5	75	5101.33
	17,5	80	5101.34
	17,5	85	5101.35
	17,5	90	5101.36
	17,5	95	5101.37
	17,5	00	5101.38
	17,5	105	5101.39
	17,5	110	5101.40
	17,5	115	5101.41
	17,5	120	5101.42
	17,5	125	5101.43
	17,5	130	5101.44
	17,5	135	5101.45
	17,5	140	5101.46



d	B	D	Ref.
69,85	16,5	80	5101.47
	16,5	85	5101.48
	16,5	90	5101.49
	16,5	95	5101.50
	16,5	100	5101.51
	16,5	105	5101.52
	16,5	110	5101.53
	16,5	115	5101.54
	16,5	120	5101.55
	16,5	125	5101.56
	16,5	130	5101.57
	16,5	135	5101.58
	16,5	140	5101.59
75	18,5	90	5101.60
	18,5	95	5101.61
	18,5	100	5101.62
	18,5	105	5101.63
	18,5	110	5101.64
	18,5	115	5101.65
	18,5	120	5101.66
	18,5	125	5101.67
	18,5	130	5101.68
	18,5	135	5101.69
	18,5	140	5101.70
80	18,5	90	5101.71
	18,5	95	5101.72
	18,5	100	5101.73
	18,5	104	5101.74
	18,5	105	5101.75
	18,5	110	5101.76
	18,5	115	5101.77
	18,5	120	5101.78
	18,5	125	5101.79
	18,5	130	5101.80
	18,5	135	5101.81
	18,5	140	5101.82
	18,5	114	5101.83
	18,5	109,5	5101.84

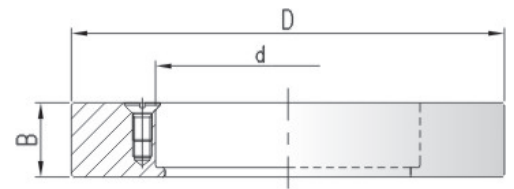



DIN 915



DIN 916



DIN 963

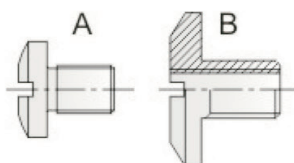
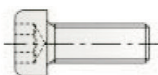
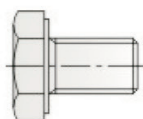
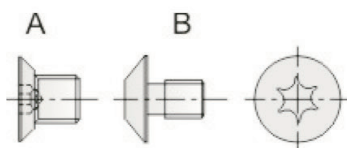
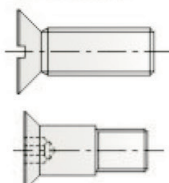

Ref.

DIN 915 Perno com oco hexagonal

M5x12 5105.001

M5x16 5105.002

M6X10 5105.003

M6X12 5105.004

M6X16 5105.005

M8X12 5105.006

M8X16 5105.007

M8X20 5105.008

M8X25 5105.009

M10X16 5105.010

M10X20 5105.011

M10X25 5105.012

M12X20 5105.013

DIN 916 Perno com oco hexagonal

M2,5X2,5 5106.001

M4X4 5106.002

M5X5 5106.003

M5X8 5106.004

M5X10 5106.005

M6X6 5106.006

DIN 963 Parafuso de cabeça de embeber

M4x8 5107.001

M5x6 5107.002

M5x8 5107.003

Parafuso com oco hexagonal

M5x13,5 5108.001

Parafuso TORX

M4x3,2 5109.001

M4x4,2 5109.002

M5x7 5109.003

M3,5x7,5 5109.004

M3,5x4 5109.005

M4x6 5109.006

M4x4 5109.007

M4x9 5109.008

Anilha de aperto para porta – lâminas de ranhurar

M4x1,6 5110.001

M4x1,7 5110.002

M4x2,3 5110.003

Parafuso com cabeça hexagonal

M10x12 5111.011

M10x17 5111.012

Parafuso com oco hexagonal

1/8" 5112.011

3/32" 5112.012

Parafuso especial de cabeça cilíndrica

M5x7/∅10 Tipo A 5113.001

M5x7/∅16 5113.002

M6x6/∅18 Tipo B 5113.003

M6x8/∅16 5113.004



CHAVE HEXAGONAL - Llave allen

		Ref.
SW 3/32"	Tipo A (chave em L)	5302.001
SW 5/64"		5302.002
SW 1,3		5302.003
SW 1,5		5302.004
SW 2		5302.005
SW 2,5		5302.006
SW 3		5302.007
SW 4		5302.008
SW 5		5302.009
SW 6		5302.010
SW 2,5	Tipo B (chave em T)	5302.101
SW 3		5302.102
SW 4		5302.103
SW 5		5302.104
SW 6		5302.105
SW 10		5302.106

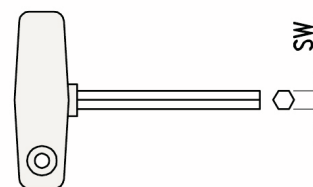
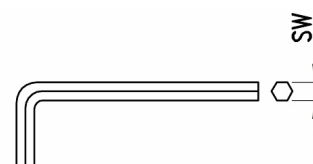

Chave TORX - Clés TORX

		Ref.
T9	Tipo A	5302.201
T15		5302.202
T9	Tipo B	5302.203
T15		5302.204
T20		5302.205

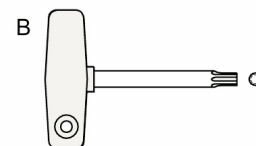
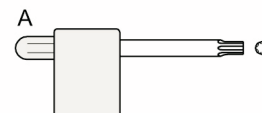

CHAVE DE UNHA - Llave de gancho

		Ref.
40/42		5302.301
45/50		5302.302
58/62		5302.303
68/75		5302.304
80/90		5302.305

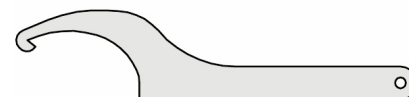

CHAVE DE BOCAS - Llave de boca

		Ref.
14/15		5302.401

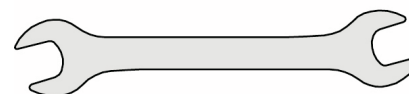

CHAVE ESPECIAL - Llave especial

		Ref.
M50x1,5		5302.501
M60x2		5302.502

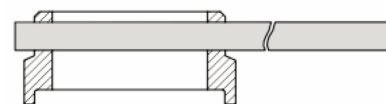

CHAVE ESPECIAL PARA A436 - Llave especial para A436

		Ref.
Para M40x1,5		5302.601
Para M50x1,5		5302.602
Para M43x1,5		5302.603

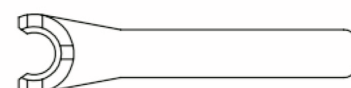

araújo&silva
ferramentas de corte

www.araujosilva.pt